

These products are manufactured at a factory which has received quality control system certification in accordance with the ISO international standards.



CERTIFICATE No. JMI-0062  
ISO 9001:1994  
BS EN ISO 9001:1994  
EN-ISO 9001:1994  
JIS Z 9901-1994

# HITACHI

## CCD Color Camera

# KP-D8

VERY SMALL SIZE / Digital



# DIGITAL

# KP-D8

## The KP-D8 is The Smallest Digital Signal Processing CCD Color Camera



The Hitachi KP-D8 is a color camera using a 410,000 pixel CCD with micro lenses, and offers a horizontal resolution of 470 TV lines and a minimum illumination of 4 lux. Thanks to the latest parts mounting technology, and DSP, the camera body weighs only 80 grams and measures approximately 42cm<sup>3</sup>. The KP-D8 operates on DC power and delivers a high quality video signal. The KP-D8 is provided with the output for an auto iris lens. Further, the KP-D8 requires a very small space for installation, enabling it's use for special purposes.

## Connection

### ■ Typical connection

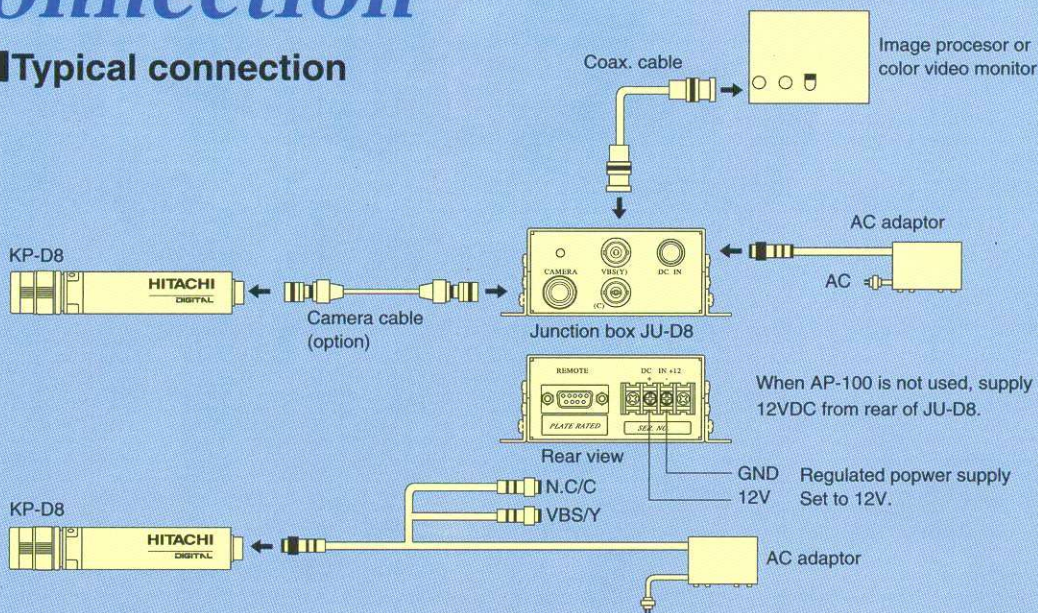



## Main features

### ● Ultra-compact, One-piece Design

A 12 volt DC power supply is all that needed in order to produce high quality video signals. Since the KP-D8 does not require a camera control unit, it can be installed in a limited space, permitting use in new and varied applications.

### ● High Sensitivity and High Resolution

A high quality interline CCD with the latest micro lens technology is used in order to achieve a minimum illumination of only 4 lux (f1.2, max AGC) and a horizontal resolution of 470 TV lines.

### ● Digital Signal Processor (DSP)

A 2H enhancer and contour correction permit sharp, clear pictures with a high signal-to-noise ratio obtained through the use of digital signal processing technology.

### ● Auto Electronic Shutter (AES)

The auto electronic shutter operates from 1/60 second (standard) to 1/180,000 second. When a fixed iris lens is used and AES is selected, the shutter speed will be changed automatically to adjust the incoming light level to the camera so that an optimum video signal is produced over varying lighting conditions.

### ● Auto White Balance Control

In the auto tracking white (ATV) mode, white balance is continually adjusted to maintain proper color balance even when the light level and color temperature of the light varies (2500K to 8000K).

This enables the camera to be used in indoor or outdoor operation without the need to manually adjust white balance. A preset mode of white balance is also available, and can be selected by dip switch or via the RS-232 port.

### ● Y/C outputs (Y/C or VBS Outputs Available)

A Y/C or composite output can be selected by the user. Using the Y/C output, a high quality, sharp clear picture is produced without the cross color artifacts produced by the normal NTSC encoding and subsequent decoding process required when using the composite signal.

### ● Remoto Control Function

Complete camera operation and selection of functions is available by use of the standard built-in RS-232 port.

Using the demonstration software and a PC the user has complete control of all camera functions. Protocol is available for those wishing to write custom software or applications for the camera.

## Accessory

### Junction box JU-D8



### Camera cables 2m/5m/10m



### Tripod adaptor TA-D8



### ■ Special mount lenses (Recommended lenses)



Iris	Type desig.	Spec.	Angle of view(Hor.)
Manual	TF812	8mm f1.2	32°
	TF316	3.7mm f1.6	72°
	TF1214	12mm f1.4	22°
Automatic	HS720JX(XE) w/3-pin plug	7mm f2.0	38°

Various C-mount lenses can be used by using the supplied C-mount conversion adaptor LA-D8. A CS-mount lens cannot be used.

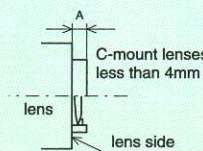

#### ● Note on lens selection

Observe the length (A) illustrated at left for the C-mount lens mounting. In case a lens having the lens mounting section in excess of the above length, the inside of the camera can be damaged.

## Specifications

Item	KP-D8(J/U)	KP-D8 E/K
Color system	NTSC	PAL
Imaging device	1/3 inch Interline transfer type CCD(with micro lens on chip)	
No. of effective pixels	768 (H) x 494 (V)	752 (H) x 582 (V)
Scanning area	4.88 (H) x 3.66 (V) (mm) (equivalent to 1/3 inch pickup tube)	4.89 (H) x 3.64 (V) (mm)
Size of cell	6.35 (H) x 7.4 (V) ( $\mu\text{m}$ )	6.5 (H) x 6.25 (V) ( $\mu\text{m}$ )
Scanning system	2:1 interlaced	
Scanning frequency	Hor.: 15.735kHz, Vert.: 59.94Hz	Hor.: 15.625kHz, Vert.: 50Hz
Sync system	Internal	
Output signal	VBS: 1.0Vp-p Video: 0.7Vp-p, positive Sync: 0.3Vp-p, negative Burst: 0.3Vp-p, 8 cycles or more Subcarrier frequency: 3.579545MHz      4.433618MHz Impedance: 75ohms unbalanced Connector: Round shape 12-pins	
Signal processing	Digital Processing (Input:9bits, Output:8bits )	
S/N ratio	48dB (Y signal, AGC:0dB, enhancer OFF, gamma OFF)	
Resolution	Hor. 470TVL (Y signal at center)	Hor. 460TVL (Y signal at center)
	Vert.: 350TVL(Y signal at center)	
Range of illumination	4 to 100,000lx (with ES lens, F1.2 AGC ON)	
Minimum illumination	4lx (F1.2 3200K, at maximum gain of AGC)	
AGC	ON/OFF switchable ON(0 to 18dB/OFF8fixed 0dB)	
Auto electric shutter	ON/OFF switchable	
Range of illumination	4 to 10,000lx (AGC: ON)	
(Range of shutter speed)	1/60s to 1/180,000s	1/50s to 1/180,000s
	Note 1:When excessively intense light comes to the CCD foralong time, the spectral filter in the CCD pixel may be deteriorated, and the color of the corresponding portion mai change. Aboyd using the camera under such condition.	
Output for ES lens	Video signal input type lens Ysignal:1.0Vp-p/High impedance Power source: DC 12V 40mA or less Connector:Miniature round, 3pins	
White balance	Control mode selectable from 3 modes below (1)Auto tracking white balance (ATW)on the indoor condition(around 3,200K) (2)Auto trackig white balance (ATW)on the outdoor condition or under mercury illumination(around 5,600K) (3)Preset mode:Preset the fixed balance condition after ATW operation Controri range of color temperature 2,500 to 8,000K	

Lens mount	Special mount (Diameter:17mm metric screw) Adaptable for C-mount with C-mount adaptor
Ambient conditions	-10 to +50degrees C, 20 to 80%RH(Note 2) Note 2:When the camera is used continuously for a long time, be sure to it at less than 40degrees C to ensure stable performance.
Storage conditions	-20 to +60degrees C, 20 to 90%RH,
Anti-vibration	3G or less, Amplitude : 10 to 55Hz Duration: 30 min. Directions: X,Y,Z Do not apply strong vibrationfor a long time.
Anti-shock characteristic	70G or less
Power supply voltage	DC 12 $\pm$ 1V
Dimensions	22 (W) x 22 (H) x 86 (D)mm Excluding lens and protrusions

### ● Standard composition

Camera .....	1	
C-mount adaptor .....	1	Wrench for lens mount fixing screw.....1
Operation manual.....	1	

### ● Optional accessories

Junction box, JU-D8  
 Camera cables, C-201KSM (2m), C-501KSM (5m), C-102KSM (10m)  
 Special mount lens, T812S (f1.2, 8mm), and other 3 lenses  
 Tripod adaptor, TA-D8  
 Plug for auto iris lens, SR38-4P3P  
 Software for remote control, RS-D8

### ● Remote control functions

Following can be controlled, using software for remote control, via RS-232C when junction box JU-D8 is used. Shutter speed, gain, Y/C output switching, manual white balance, enhancer level, gamma, chroma level, etc.

### Pin arrangement of DC IN/VIDEO connector

Pin No.	Signal name	Remarks
1	GND	DC ground
2	+12V	12VDC input
3	GND (VBS/YC)	Composite color video signal ground
4	VBS/YC	Luminance signal output
5	GND (TX)	Serial data output ground
6	TX	Serial data output (3.3VTTL)
7	RX	Serial data input (3.3VTTL)
8	GND (C)	Chroma signal ground
9	-/C	Chroma signal output
10	GND	DC ground
11	+12V	DC power input
12	GND (RX)	Ground for serial data input

## Dimensions



**CAUTION:**To product ensure safe operation, please read the instruction manual before using this product.

*These Specifications are subject to change without notice.*

# HITACHI DENSHI (Europa) GmbH

Weiskircher Str. 88  
 63110 Rodgau, Germany  
 T. 06106-6992-0  
 Fax 06106-16906

[http://ourworld.compuserve.com/homepages/Hitachi\\_Denshi](http://ourworld.compuserve.com/homepages/Hitachi_Denshi)  
 E-Mail: 100443.2014@compuserve.com