

Fully Digital Multi-Standard Camera SK-3020P



**SK-3020P with
Studio Adaptor (SA-3100)**

Fully Digital Multi-Standard Camera SK-3020P

The Hitachi SK-3020P multi-standard broadcast camera is designed for today's new generation of High Definition Digital Television Program Production and Broadcast Systems with high cost-to-performance.

With the use of high performance 2,200,000-pixel CCDs, our HDTV cameras satisfy the requirements of today's varied digital television formats.

Standard Definition serial digital interface (SDI) formats as 480i and 575i are available as optional outputs.

Hitachi's SK-3020P camera series employs low power digital processors (DSP) and 14-bit Analog to Digital converters. These two technologies are the main attributes for high-quality video performance quantified by high resolution and superior signal to noise ratio specifications. This new compact and lightweight portable camera head

design weighs merely 4.7Kg including its viewfinder.

The CCU height is a compact 2 RU units (88mm) even in half-rack width (215mm). In addition, the power consumption of the camera has been dramatically reduced.

All of the HDTV, SDTV signal circuits and power supply have been densely integrated into 3 plug-in modules inside the new Camera Control Unit, thereby realizing degrees of high reliability and easy maintenance.

Hitachi introduces a new member of its advanced HDTV cameras.

The camera head can be operated in stand-alone mode or via Fiber-Optic cable connected to its new compact, half-rack width, Camera Control Unit.

Key Features

Durable & Lightweight camera body designs

The camera head and viewfinder are a lightweight 4.7 kg (approx). Our engineers have designed the camera head with completely flat sides, void of protrusions that impede ease of use by a camera person.

Advanced Imaging Sensors

New implementation of advanced 2.2 million pixels IT-CCDs provides high sensitivity, high-resolution and high S/N.

Efficient Digital Processing (DSP) and 14-bit Analog to Digital conversion

Hitachi's implementation of its own single, low power consumption LSI-DSP, provide advanced image enhancing features as independent control of 6-vector, color adjustment, linear masking, flesh-tone masking and Knee Saturation.

Furthermore, high-bandwidth, low-noise 14-bit analog-to-digital converters attribute to pristine picture quality and definition.

Highly Integrated CCU designs

The height of the standard Camera Control Unit (CCU model CU-3300) in the SK-3020P system is (88mm) high and, of 2-RU EIA 19-inch rack width. This new and highly integrated design helps sharply reduce the power consumption of the camera system to less than 150VA.

High reliability and easy maintenance have been realized by integrating the HDTV, SDTV signal handling and power supply electronics into 3 plug-in modules inside the CCU. This design philosophy is also used with the half-rack CCU model CU-3100.

Down-converted Standard Definition outputs are provided in the optional "up/down converter" module available for both CCU models (CU-3300, CU-3100). This "up/downconverter" module allows one to select all-analog IO's, all-digital (SDI) IO's or a mix of the two.

DTL and Masking functions for High Definition and Standard Definition signals are independently controlled by separate DSP processors. Digital encoders for 480i NTSC or 575i PAL composite signals provide stable, high quality images.

System diagnostics and status information are superimposed on the Monitor Video output in HD-SDI format. High quality return (AUX) video inputs can be HD or SD processed by the up/down converter module.

Half-rack wide, Ultra-compact Camera Control Unit

The CU-3100 is one of the CCU options for the SK-3020P. High cost-to-performance ratios and operational reliability have been achieved through its compact size, low-power consumption design, and standard HD-SDI inputs / outputs. Other SD video outputs such as D1-SDI & VBS are provided in the optional down-converter module for configuration optimization. The compact camera operation panel model RU-3300N can be installed in the front of the CU-3100 CCU, saving even more space.



CU-3100



RU-3300N

On-line self-diagnostics

The self-diagnostic system of the SK-3020P displays and alarms upon any abnormality of operation in the camera system including digital optical fiber transmission system between the camera head and the CCU.

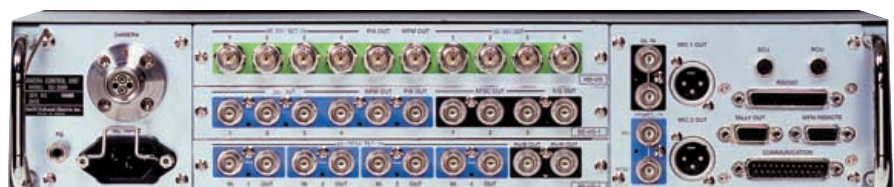

CU-3300

System Configurations

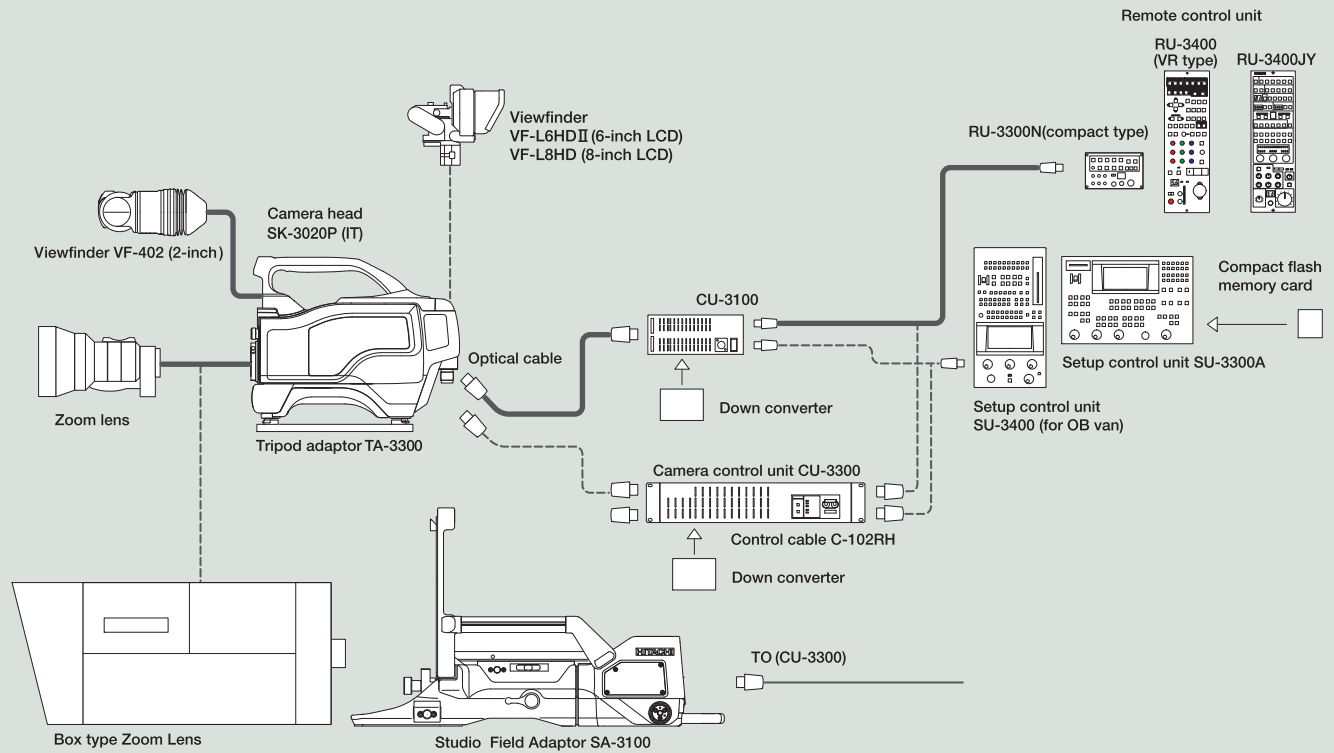

Accessories

SA-3100 STUDIO & FIELD ADAPTER

A flexible full studio camera can be configured by use of the studio field adapter.

The studio & field adaptor model SA-3100 can be easily built-up in a few minutes with the SK-3020P camera heads.

AUX /RET Video select, VF Graticule, Tally and Intercom controls are located in the rear operation panel of the studio field adaptor so that functionality is equivalent to a full-body studio camera.



SU-3300A SET UP CONTROL UNIT

The setup control unit SU-3300A provides access and complete control of up to 12 SK-3020Ps. The built-in vacuum fluorescent display panel (VFD) screen allows for intuitive and simple operation.

The half rack SU-3400 setup control unit minimizes the installation space needed inside an OB van and, can be used like an SU-3300A.



SU-3300A

VF-L6HD II 6-INCH LCD COLOR VIEWFINDER

The color viewfinder model VF-L6HD II (6 inch LCD) can be used with the SK-3020P camera bodies to configure a compact studio use camera. That can also be mounted directly on the SK-3020P camera heads.



RU-3400 REMOTE CONTROL UNIT

The compact size RU-3300N is suitable for news studio use etc., whereas the RU-3400 has many functions for video control. The remote control units can be used without the system SCU. This makes them convenient for OB van use.

RU-3400



Specifications

System	1080 59.94i/50i
Imaging Device	2/3" 2.2M pixel IT-CCD sensor
Effective pixels	1920 x 1080
Optical systems	F1.4 prism
Optical filters	ND: 3200K, 5600K+1/16, 5600K, 5600K+1/64 Secondary filter wheel factory option
Sensitivity	2000l x F11 (3200K, 89.9% reflection)
Signal-to-noise ratio	56dB (HD-SDI Y:30MHz)
Horizontal resolution	greater than 1000TV lines (typ.)
Registration	0.02% (excluding lens characteristics)
Power consumption	Camera Head: 45 W approx. (with View Finder)
Dimensions (W x H x D) mm	115(W) x 278(H) x 365(D) mm
Mass	4.7 kg approx. (including 2" viewfinder)
Operating temperature	from -10 to +40 °C
Head outputs	Line : HD-SDI x1, PROMPT (VBS)
Head inputs	MIC x2

	CU-3100	CU-3300
Power consumption	100VA approx. (Including power supply for camera head)	150VA approx. (Including power supply for camera head)
Dimensions (W x H x D) mm	215 x 88 x 450	430 x 88 x 450
Mass	6 kg approx.	15 kg approx.
Operating temperature	from 0 to +40 °C	
Maximum cable length	Optical fiber multi cable 1000m (power supply) 3000m (no power supply)	
CCU output HDTV	HD-SDI : Line x3, PIX x1, WFM x1	HD-SDI : Line x3, PIX x2, WFM x1
CCU output SDTV	NTSC (480i) or PAL (575i) (option)	NTSC (480i) or PAL (575i) (option)
LINE	D1 or VBS x 3 RGB (or Y PB PR) x1	D1x 3, VBS x 3 RGB (or Y PB PR) x1
PIX	D1 or VBS x1	D1 or VBS x 2
WFM	D1 or VBS x 1	
Audio	Analog x 2	Analog x 2, digital x 1 (option)
CCU inputs	RET HD-SDI x2 SDTV D1 or VBS x2 (option)	HD-SDI x2, x4 (option) SDTV D1 or VBS x 4
PROMPT	VBS x 1	
Gen-lock	BB or HDTV Tri-level sync	

Dimensions

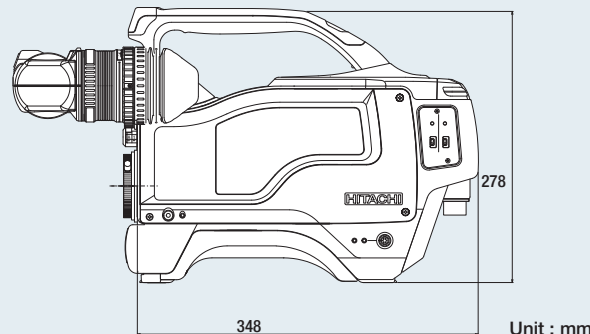

CAUTION: To ensure safe operation, please read the instruction manual before using this product.

These Specifications are subject to change without notice.

Hitachi Kokusai Electric Inc.

Head Office : 14-1, Sotokanda 4-chome, Chiyoda-ku, Tokyo 101-8980, Japan
Phone : +81(0) 3-6734-9432, Fax : +81(0) 3-5209-5942
URL : <http://www.h-kokusai.com>

Hitachi Kokusai Electric (Shanghai) Co., Ltd. Beijing Branch
Room 1413, Beijing Fortune Building, 5 Dong San Huan Bei-Lu, Chao Yang District, Beijing
Phone : +86(0) 10-6590-8755/8756, Fax : +86(0) 10-6590-8757

Hitachi Kokusai Electric America, Ltd. URL : <http://hitachikokusai.us>
: 150 Crossways Park Drive, Woodbury, New York 11797, U. S. A.
Phone : (+1) 516-921-7200, Fax : (+1) 516-496-3718

Headquarters and Northeast Office
West Office : 371 Van Ness Way, Suite 120 Torrance, CA. 90501, U. S. A.
Phone : (+1) 310-328-6116, Fax : (+1) 310-328-6252

Midwest Sales : Phone : (+1) 330-334-4115, Fax : (+1) 516-496-3718
Service (+1) 989-345-5379

South Sales : Service (+1) 256-774-3777
Parts Center : Phone : (+1) 516-682-4435, Fax : (+1) 516-921-0993
Latin Sales : Phone : (+1) 516-682-4420, Fax : (+1) 516-496-3718

Hitachi Kokusai Electric Canada, Ltd. URL : www.hitachikokusai.ca
Head Office : 1 Select Avenue Unit#12 Scarborough, Ontario M1V 5J3, Canada
Phone : (+1) 416-299-5900, Fax : (+1) 416-299-0450
Eastern Office : 5795 Chemin St. Francois St. Laurent, Quebec H4S 1B6, Canada
Phone : (+1) 514-332-6687, Fax : (+1) 514-335-1664

Hitachi Kokusai Electric Europe GmbH

Head Office : Weiskircher Straße 88, Jügesheim D-63110 Rodgau, Germany
Phone : +49(0) 6106-69920, Fax : +49(0) 6106-16906
URL : www.hitachi-ke-eu.com
General email address : info@hitachi-ke-eu.com

Hitachi Kokusai Electric U.K. Ltd.

Head Office : Windsor House, Britannia Road, Waltham Cross, Hertfordshire EN8 7NX, United Kingdom
Phone : +44(0) 845-121-2177, Fax : +44(0) 845-121-2180
General email address : uksales@hitachi-ke-eu.com



CERTIFICATE No.
JMI-0062
ISO 9001/BS 5750P1t
EN 29001/JIS Z9901