

Preliminary

Fully Digital Multi-Standard Camera SK-3200 Series

SK-3200



SK-3200P with SA-3100



SK-3200P



SK-31B



SK-3200 series

The Hitachi SK-3200 multi-standard broadcast camera series is designed for today's new generation of High Definition Digital Television Program Production and Broadcast Systems.

With the use of high performance 2,200,000-pixel CCDs, our HDTV cameras satisfy the requirements of today's varied digital television formats.

New and available with the SK-3200 series is the choice of native progressive or interlaced scanned HDTV CCDs with 720p or 1080i outputs. Standard Definition serial digital interface (SDI) formats as 575i are available as optional outputs.

Hitachi's SK-3200 camera series employs low power digital processors (DSP) and 14-bit Analog to Digital converters. These two technologies are the main attributes for high-quality video performance quantified by high resolution and superior signal to noise ratio specifications.

This new compact and lightweight portable camera head design weighs

merely 4.7Kg including its viewfinder. The CCU height is a compact 2 RU-units (88mm). In addition, the power consumption of the camera has been dramatically reduced.

All of the HDTV, SDTV signal circuits and power supply have been densely integrated into 3 plug-in modules inside the new Camera Control Unit, thereby realizing degrees of high reliability and easy maintenance.

Hitachi introduces a new member of its advanced HDTV cameras. The model SK-31B is a fully new design compact box-type camera that can be integrated in and, operated with the SK-3200 series system. The SK-31B camera head weighing just 3Kg is perfectly suited for News Studio Robotic systems, Crane/ Track Cameras, Helicopter and P.O.V. applications. The camera head can be operated in stand-alone mode or via Fiber-Optic cable connected to its new compact, half-rack width, Camera Control Unit.

Key Features

Durable & Lightweight camera body designs

The camera head and viewfinder models SK-3200P is a lightweight 4.7 kg (approx).

Our engineers have designed the camera head with completely flat sides, void of protrusions that impede ease of use by a cameraperson.

Advanced Imaging Sensors

New implementation of advanced 2.2 million pixels IT-CCDs provides high sensitivity, high-resolution and high S/N.

Efficient Digital Processing (DSP) and 14-bit Analog to Digital conversion

Hitachi's implementation of its own single, low power consumption LSI-DSP, provide advanced image enhancing features as independent control of 6-vector, color adjustment, linear masking, flesh-tone masking and Knee Saturation.

Furthermore, high-bandwidth, low-noise 14-bit analog-to-digital converters attribute to pristine picture quality and definition.

New Design Compact, Point-of-View camera head

Hitachi's new box-type camera model SK-31B is a family member of the SK-3200 series system.

A high level of performance and functionality is achieved by employing the same electronics, as the SK-3200 series including transmission system and software. This ease of use is also augmented by the SK-31B's ability to use the same peripherals or system components of the SK-3200 such as CCUs,



SCUs, Optical Cables and RCUs.

Self-contained or "Stand-alone" operation can be achieved by simply providing DC power to the SK-31B. The SK-31B camera provides native SMPTE-292M HD-SDI (1.485Gbps) video output directly from the head. This local output provides additional configuration flexibility in complex system designs or simply for viewfinder or QA monitoring.

Highly Integrated CCU designs

The height of the standard Camera Control Unit (CCU model CU-3300) in the SK-3200 system is (88mm) high and, of 2-RU EIA 19-inch rack width. This new and highly integrated design helps sharply reduce the power consumption of the camera system to less than 150VA.

High reliability and easy maintenance have been realized by integrating the HDTV, SDTV signal handling and power supply electronics into 3 plug-in modules inside the CCU. This design philosophy is also used with the half-rack CCU model CU-3100 designed for the SK-31B.

HD-SDI signal outputs of 1080i or 720p are available as standard depending on the initial selection of CCDs. Down-converted Standard Definition outputs are provided in the optional "up/down converter" module available for both CCU models (CU-3300, CU-3100). This "up/down-converter" module allows one to select all-analog IO's, all-digital (SDI) IO's or a mix of the two.

DTL and Masking functions for High Definition and Standard Definition signals are independently controlled by separate DSP processors. Digital encoders for 575i PAL composite signals provide stable, high quality images.

System diagnostics and status information are superimposed on the Monitor Video output in HD-SDI format. High quality return (AUX) video inputs can be HD or SD, processed by the up/down converter module.



System Configurations

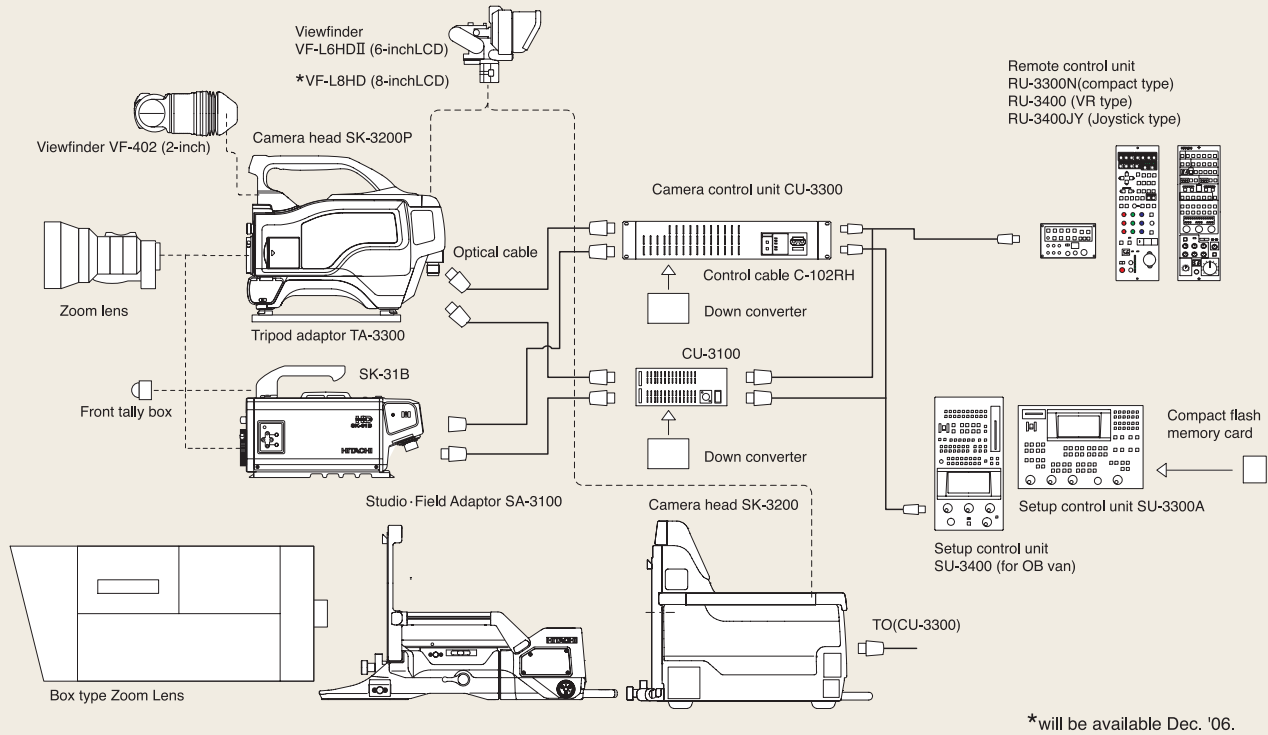

On-line self-diagnostics

The self-diagnostic system of the SK-3200 series displays and alarms upon any abnormality of operation in the camera system including digital optical fiber transmission system between the camera head and the CCU.

Half-rack wide, Ultra-compact Camera Control Unit

The CU-3100 is one of the CCU options for the SK-3200P / SK-31B.

High cost-to-performance ratios and operational reliability have been achieved through its compact size, low-power consumption design, and standard HD-SDI inputs / outputs. Other SD video outputs such as D1-SDI & VBS are provided in the optional down-converter module for configuration optimization. The compact camera operation panel model RU-3300N can be installed in the front of the CU-3100 CCU, saving even more space.

Accessories

SA-3100 STUDIO & FIELD ADAPTER

A flexible full studio camera can be configured by use of the studio field adapter, 6-inch color LCD viewfinders and Box-type Zoom lens. The studio & field adaptor model SA-3100 can be easily built-up in a few minutes with the SK-3200P camera heads.



AUX /RET Video select, VF Graticule, Tally and Intercom controls are located in the rear operation panel of the studio field adaptor so that functionality is equivalent to a full-body studio camera.

VF-L6HD II 6-INCH LCD COLOR VIEWFINDER

The color viewfinder model VF-L6HD II (6 inch LCD) can be used with the SK-3200P camera bodies to configure a compact studio use camera. That can also be mounted directly on the SK-3200P camera heads.



SU-3300A SET UP CONTROL UNIT

The setup control unit SU-3300A provides access and complete control of up to 12 SK-3200s. The built-in vacuum fluorescent display (VFD) screen allows for intuitive and simple operation.



The half rack SU-3400 setup control unit minimizes the installation space needed inside an OB van and, can be used like an SU-3300A.

RU-3400 REMOTE CONTROL UNIT

The compact size RU-3300N is suitable for news studio use etc., whereas the RU-3400 has many functions for video control such as "one-touch color temperature". The remote control units can be used without the system SCU. This makes them convenient for OB van use.



RU-3400

Specifications

	SK-3200	SK-3200P	SK-31B
System	HDTV 1125 59.94i/50i or 720 59.94P/50P		
Imaging Device	2/3"2.2M pixel or 2/3" 1.0M 720P CCD		
Effective pixels	1920 x 1080 or 1280 x 720		
Optical systems	F1.4 prism		
Optical filters	ND:CAP:100%,50%,12.5%,1.6% CC:Cross,3200K,4300K,6300K,8000K (5600K:electronic filter)		
Sensitivity	2000 lx F11 (3200K,89.9% reflection) or F10 (720P)		
S/N	56dB (HD-SDI Y:30MHz)		
Horizontal resolution	greater than 1000 TV lines typ or 700 TV lines typ (720P)		
Registration	0.02%(excluding lens characteristics)		
High gain	-3,0, +3, +6, +9, +12dB		
Camera head Power consumption	43W		40W
Dimensions(WH x D)mm	250 x 365 x 394	115 x 278 x 365	118 x 143 x 324
Mass	25kg	4.7kg(including 2"viewfinder)	3kg
Operating temperature	-10 to 40°C		
Camera head output	HD-SDI x 1(SMPTE 292M)		
	HD-SDI(RET) x 1	—	—
	PROMPT(VBS)		—
Camera head input	MIC: x 2		—

	CU-3300	CU-3100
Power consumption	150VA (Including power supply for camera head)	100VA (Including power supply for camera head)
Dimensions(W x H x D)mm	430 x 88 x 450	215 x 88 x 450
Mass	15kg	6kg
Operating temperature	0 to 40°C	
Maximum cable length	Optical fiber multi cable 1000m(power supply) 3000m(no power supply)	
CCU output HDTV	HD-SDI: LINE x 3, PIX x 2, WFM x 1	HD-SDI: LINE x 3, PIX, WFM x 1
	NTSC(480i) or PAL (575i) OPTION	NTSC(480i) or PAL (575i) OPTION
SDTV	LINE D1 x 3, VBS x 3, RGB(or Y.PB.PR)	LINE D1 or VBS x 3, RGB(or Y.PB.PR)
	PIX D1 or VBS x 2	PIX D1 or VBS x 1
	WFM D1 or VBS	
	AUDIO analog x 2, digital x 1(OPTION)	AUDIO analog x 2 (UP/Down converter option)
CCU input	RET HD-SDI x 2, x 4 (OPTION) SDTV D1 or VBS x 4	RET HD-SDI x 2, D1 or VBS x 2 (OPTION)
	PROMPT VBS	
	Analog Gen-lock BB or HDTV Tri-level SYNC	

Dimensions

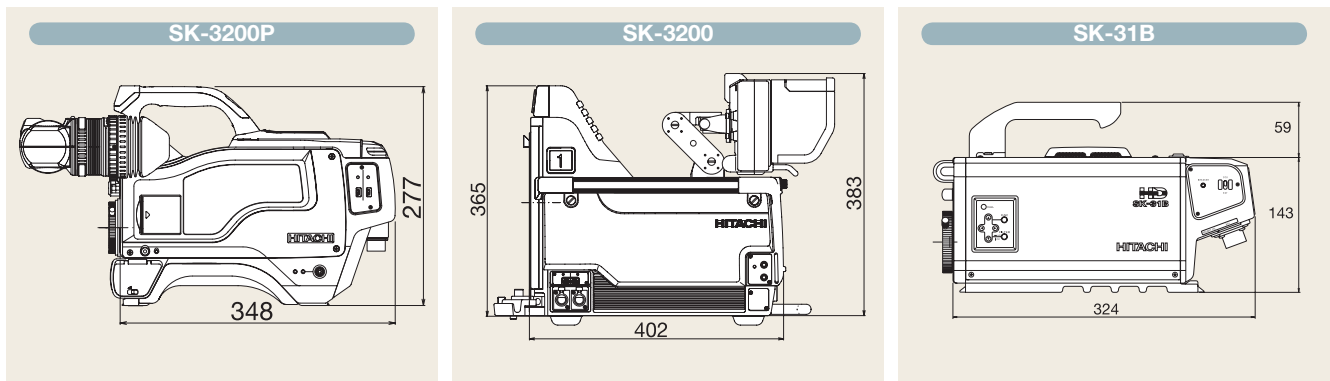

CAUTION: To ensure safe operation, please read the instruction manual before using this product.

These Specifications are subject to change without notice.

Hitachi Kokusai Electric Inc.

Head Office : 14-1, Sotokanda 4-choume, Chiyoda-ku, Tokyo 101-8980, Japan
Phone : +81(0) 3-6734-9432, Fax : +81(0) 3-5209-5942
URL : <http://www.h-kokusai.com>

Hitachi Kokusai Electric (Shanghai) Co., Ltd. Beijing Branch
Room 1413, Beijing Fortune Building, 5 Dong San Huan Bei-Lu, Chao Yang District, Beijing
Phone : +86(0) 10-6590-8755/8756, Fax : +86(0) 10-6590-8757

Hitachi Kokusai Electric America, Ltd. URL : <http://hitachikokusai.us>
: 150 Crossways Park Drive, Woodbury, New York 11797, U. S. A.
Headquarters and Northeast Office : Phone : (+1) 516-921-7200, Fax : (+1) 516-496-3718
West Office : 371 Van Ness Way, Suite 120 Torrance, CA, 90501, U. S. A.
: Phone : (+1) 310-328-6116, Fax : (+1) 310-328-6252

Midwest Sales : Phone : (+1) 330-334-4115, Fax : (+1) 516-496-3718
Service (+1) 989-345-5379

South Sales : Service (+1) 256-774-3777
Parts Center : Phone : (+1) 516-682-4435, Fax : (+1) 516-921-0993
Latin Sales : Phone : (+1) 516-682-4420, Fax : (+1) 516-496-3718

Hitachi Kokusai Electric Canada, Ltd. URL : www.hitachikokusai.ca
Head Office : 1 Select Avenue Unit#12 Scarborough, Ontario M1V 5J3, Canada

Eastern Office : Phone : (+1) 416-299-5900, Fax : (+1) 416-299-0450
: 5795 Chemin St. Francois St. Lau rent, Quebec H4S 1B6, Canada
Phone : (+1) 514-332-6687, Fax : (+1) 514-335-1664

Hitachi Kokusai Electric Europe GmbH

Head Office : Weiskircher Straße 88, Jügesheim D-63110 Rodgau, Germany
Phone : +49(0) 6106-69920, Fax : +49(0) 6106-18906
URL : www.hitachi-ke-eu.com
General email address : info@hitachi-ke-eu.com

Hitachi Kokusai Electric U.K. Ltd.

Head Office : Windsor House, Britannia Road, Waltham Cross, Hertfordshire EN8 7NX, United Kingdom
Phone : +44(0) 845-121-2177, Fax : +44(0) 845-121-2180
General email address : uksales@hitachi-ke-eu.com



CERTIFICATE No.
JMI-0062
ISO 9001/BS 5750Pt1
EN 29001/JIS Z9901