

Preliminary

HITACHI

DIGITAL CAMERA



Z-2500

Z-2500

The Hitachi Z-2500 offers Professional users the best combination of features and price. The Z-2500 incorporates added new technology advancements, performance and functionality that continue the tradition and popularity the Z-series Hitachi cameras are know for.

Budget-conscious users now benefit from the use of Hitachi's own DSP IC's and the implementation of the latest generation of 12-bit Analog to Digital Converters; technologies which add up to high-quality images with superb resolution and low noise qualities.

Outstanding Features

Resolution 900TV line

An outstanding 900 TV Lines of resolution are achieved through the use of Hitachi's own Digital Signal Processor and new 2/3-inch, 410,000 pixel IT-CCDs.

Next-Generation DSP

Hitachi's unique DSP technology encompasses the video digital processing and the encoder into a single LSI device. This single chip 3 million gates 0.18 μ m DSP design reduces the size, power consumption and greatly enhances stability.

The 12 bit A/D converter and 20 to 30 bit DSP processing provide a high S/N ratio and wide dynamic range.

Signal to Noise Ratio 65dB

With the new digital noise reduction and low noise DSP technology, a S/N ratio of 65dB is achieved. This new technology assures clear low noise images while operating in the high gain modes.

Sensitivity - F11(2000 lx)

A total of +36dB of gain is available for reproducing low light scenes down to 0.5 lx (F1.4). The +36dB gain is a combination of +24dB high gain and +12dB digital gain.

Versatile CCD Shutter

Four modes of shutter operation are provided : Five Preset electronic shutter speeds, Lock Scan to image computer monitors without flicker, Auto Electronic Shutter (AES) maintains the video level with a fixed lens f-stop, and CC Frame offers improved vertical resolution.

Digital Processing Improves Image Highlight Quality

Dyna-Chroma and Auto Knee

The auto knee provides a wide dynamic range by compressing the video above 100IRE. Dyna-chroma restores color saturation to scene highlights above 100IRE.

Automatic Flesh Tone Detail

Flesh tone detail smooths and softens facial lines and blemishes without sacrificing overall scene detail. Automatic flesh tone detail provides an easy and fast means to optimize flesh tone detail.

Variable Detail Boost Frequency

The detail center frequency is user selectable to match the detail signal to the scene.

6-Vector and Linear Matrix

The 6-vector color corrector and linear matrix provide the user a wide latitude in subjective image color control. The linear matrix provides overall color control and the 6-vector color corrector provides independent control of the hue and saturation for each of the three primary and three secondary colors.



Special Gamma

Adjusts the initial gamma gain to optimize the reproduction of the dark areas in a scene.

Gray Scale Automatic Setup

This "through the lens" automatic is used in combination with a standard gray scale chart to automatically setup gain, gamma, black and flare. Markers are provided in the viewfinder to aid in the positioning of the gray scale chart and the iris is automatically adjusted to the correct video level.

Automatic shading

Automatic shading corrects white vertical shading at the push of a button. This feature provides separate setups to optimize the X1 and X2 lens extender positions.

Extensive User-Friendly Features

• Quick Focus

Quick Focus automatically opens the iris then sets the video level with the electronic shutter. With the resulting shallow depth of focus, the exact focus point can be set easily.

• Two User-Programmable Switches (CS-1, CS-2)

The user can assign full auto, quick focus or contrast to either of the two programmable switches for ease of operation.

• Full Auto

The built-in automatic electronic shutter (AES) and automatic iris maintain the video level even with radically changing light levels. Real-time automatic white balance corrects for color temperature variations due to changing types of lighting conditions.

- Four scene files are provided to store and recall functions such as gain, detail, masking, gamma and other settings.
- Camera ID, date and time are displayed on the color bar display.
- Audio test tone (1kHz) is output when color bars are selected.

Viewfinder Displays

- The viewfinder displays the function tree menus.
- Status display
Indicators for zoom and focus (with compatible lenses), iris F-stop, color temperature for auto white balance and other functions are displayed.

• Two mode zebra

Menu selection of over-level or between range zebra is provided.

• Viewfinder V-Detail

Vertical detail is enhanced in both the 1.5-inch VF (GM-9) and 5-inch VF (GM-51) viewfinders for easy lens focus. Horizontal detail is also provided.

High Performance 1.5 inch Viewfinder (GM-9)

- The 600 TV line resolution assures easy focus.
- Large aperture lens improves viewfinder viewing.
- Front-back, left-right and tilt positioning is provided for optimum user comfort. The bayonet mount provides a direct connection to the camera eliminating the need of a cable.
- Rotates to a perpendicular position for convenient carrying.



Advanced Ergonomics

- New low center of gravity design.
- Main operation switches are grouped forward for easy access.
- Featherweight design (camera head 2.6 kg) is ideal for portable use.
- Adjustable shoulder pad position and non-slip finish provide on-the-shoulder balance, comfort and confidence.

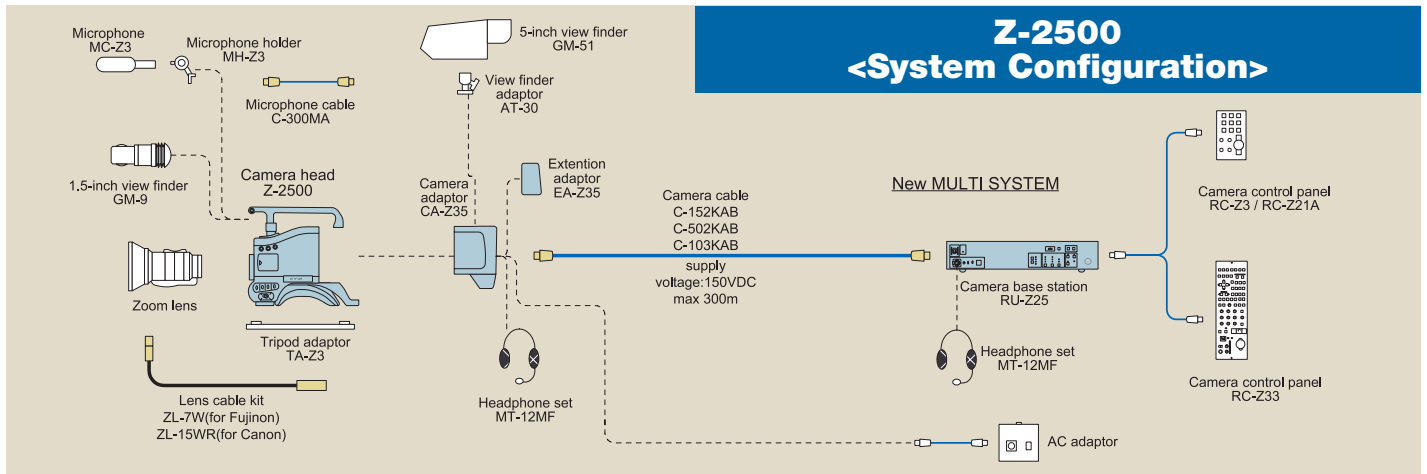

FLEXIBLE CHOICE OF REMOTE CONTROL UNITS

Suggested System Configurations

Studio system: RU-Z25 Remote Operation Unit, CA-Z35 Camera Adapter, RC-Z3/RC-Z21A/ RC-Z33 Camera Control Panel, and GM-51 5-inch view finder.

Studio Operation Enhancement

The optional EA-Z35 Extension Adapter adds (used with the RU-Z25) intercom channel PD/ENG switching, prompter video output and a call button to alert a video operator by the Camera Base Station or Camera Control Panel.

RC-Z33 Camera Control Panel

The RC-Z33 Camera Control Panel has 11 potentiometers to control the Z-2500 camera.

RU-Z25 Camera Base Station

The new Camera Base Station model RU-Z25 includes all the essential camera system features and functions and offers a high picture quality in demanding production studio applications. Production Switcher independent Green Tally and Red Tally are available as standard features. Prompter video and power at the camera head are also standard functions offered.



ACCESSORIES



CA-Z35
Camera adaptor for RU-Z25



MC-Z3
Microphone



MH-Z3
Microphone holder



C-300MA
Microphone cable



GM-9
1.5-inch view finder



GM-51
5-inch view finder



AT-30
View finder adaptor for GM-51



MT-12MF
Headset



TA-Z3
Tripod adaptor



C-502KAB/C-152KAB/C-103KAB
Camera cable



EA-Z35
Extension adaptor for CA-Z35



A20 x 8.6BRM-24
Zoom lens



YJ19 x 9BKRS
Zoom lens

SPECIFICATIONS : Z-2500 Camera Head

Color System	NTSC
Optical system	2/3" F1.4 prism
Pickup system	RGB 3IT-CCD, 2/3" Image format
Imaging size	4 : 3 8.8 x 6.6mm
Picture elements (pixels)	Total 811(H) x 508(V) Effective 768(H) x 494(V)
Sync system	Internal or genlock
Horizontal resolution	900 TV lines (4 : 3)
Signal-to-noise ratio	65dB (typical) (Gamma : 1, DTL:OFF, Gain : 0dB, Y OUT)
Standard sensitivity	F11 at 2000 lx
Minimum illumination	0.5 lx F1.4 / 0.8 lx F1.8 (Gain : +24dB, digital gain : on)
Gamma correction	0.35 to 1.0 (ON/OFF switchable)
Geometric distortion	All zones : less than measurement limit (excluding lens)
Registration	All zones : less than 0.05% (excluding lens)
Optical filters	3200K, 5600K +1/16ND, 5600K, 5600K+1/64ND
Vertical detail correction	2H
DTL controls	DTL LEVEL, DTL FREQ, FLESH TONE, LEVEL DEP, CRISP, H-V BAL, SOFT DTL, etc.
Lens mount	Bayonet (Backfocus : 48mm in air)
Gain selector	Low : 0dB Mid : +6 / +9 / +12dB High : +12 / +18 / +24dB Remote mode : 0dB to +24dB (3dB steps)
Digital-Gain function	Gain is increased +6dB, +12dB by Internal processing of DSP
Scene file	4 scene files Items: gain, DTL, masking, gamma, electronic shutter, auto iris mode, contrast, etc.
Electronic shutter	Preset mode 1/100, 1/250, 1/500, 1/1000, 1/2000 CC FRAME Lock SCAN mode : approx 1/61 to approx. 1/2000 (in 1H steps); Automatic Electronic Shutter (AES) mode : (up to 4 lens-stops)
Input signals	1. Genlock input (BNC or multi-connector) : VBS 1.0Vpp ±3dB or black burst/75Ω (sync 0.3±0.1Vpp, burst : 0.3±0.1Vpp) 2. Viewfinder AUX input (multi-connector) : VBS 1.0Vpp ±3dB / 75Ω
Output signals	1. Video output (BNC) VBS 1.0Vpp / 75Ω 2. VTR output 1 (multi-connector) VBS 1.0Vpp / 75Ω 3. VTR output 2 (multi-connector) a : Composite signal: VBS 1.0Vpp / 75Ω b : Y/C output : Y : 1.0Vpp / 75Ω, C : 0.286Vpp (burst), c : RGB output : RGB : 0.714Vpp / 75Ω d : Component output: VS : 1.0Vpp / 75Ω R-Y, B-Y : 0.7Vpp / 75Ω (BETACAM, 75% color bars), 0.525Vpp / 75Ω (MII, 75% color bars) 4. Monitor output (BNC) VBS 1.0Vpp / 75Ω, with characters 5. Audio output (multi-connector) -20dBm or -60dBm
Ambient temperature	Operating: -10 to +45°C (+14 to +113F) Storage: -20 to +60°C (-4 to +140F)
Power requirement	12 V DC (+10.5VDC to +17VDC)
Power consumption	Approx. 9.8W (excluding GM-9, camera adapter)
Dimensions	125(W)x268(H)x160(D)mm (excluding camera adapter)
Mass	Approx. 2.6kg (5.7 lb) (excluding GM-9, lens and camera adapter)

SPECIFICATIONS : GM-9 1.5-inch Viewfinder

Input signal	VS 1.0Vpp, sync negative
CRT	1.5" B/W
Resolution	Approx. 600 TV lines (horizontal center)
Aspect ratio	4:3
LED display	TALLY, BATT, SAVE, (!) Warning indicator : out of standard application
Controls	Brightness, Peaking, Contrast, Front tally ON/OFF
Power supply	9V DC
Power consumption	Approx. 1.4W
Mass	Approx. 0.6kg (1.3 lb)

SPECIFICATIONS : RU-Z25

OUTPUT signals	LINE 1 / 2	VBS 1.0Vpp/75Ω
	MON	VBS 1.0Vpp/75Ω
	RGB R-Y, Y, B-Y	V : 0.7Vpp VS1.0Vpp/75Ω
	AUDIO output	0dB, 600Ω, one system
INPUT signals	PROMPT	VBS 1.0Vpp/75Ω or loop-through
	AUX VIDEO	VBS 1.0Vpp/75Ω or loop-through
	GENLOCK	BB 0.6Vpp/75Ω or loop-through
	TALLY	Closure or Voltage (24V)
	INTERCOM	XLR-5pin Corresponding to dynamic mic
Power requirements		117V AC, 60Hz
Power consumption		Approx. 125W
Maximum cable length		Approx. 300m (980 ft)
Ambient temperature		5 to 40°C (41 to 104°F)
Dimension		482(W) x 88(H) x 300(D)mm (19.0 x 3.5 x 11.8 in)
Mass		Approx. 9kg (20 lb)

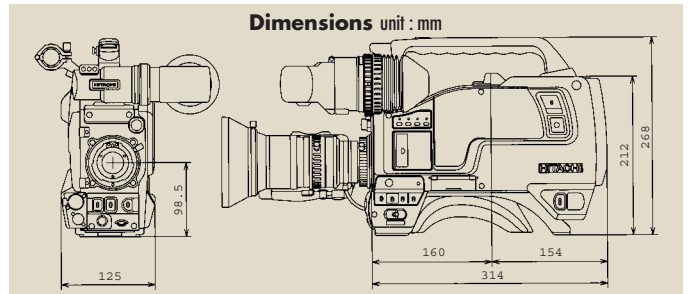

CAUTION : To ensure safe operation, please read the instruction manual before using this product.

These Specifications are subject to change without notice.

Hitachi Kokusai Electric Inc.

Head Office : 14-20, Higashi-Nakano 3-choume, Nakano-ku, Tokyo 164-8511, Japan
Phone : +86 (0) 10-6590-8755/8756, Fax : +86 (0) 10-6590-8757
URL: <http://www.h-kokusai.com>

Beijing Office

Beijing Fortune Building 5, Dong San Huan Bei-4u, Chao Yang District, Beijing, 100029 China
Phone : +86 (0) 10-6590-8755/8756, Fax : +86 (0) 10-6590-8757

Hitachi Denshi America, Ltd. URL: <http://www.hdal.com>

Headquarters and : 150 Crossways Park Drive, Woodbury, New York 11797, U. S. A.
Northeast Office : Phone : (+1) 516-921-7200, Fax : (+1) 516-496-3718

West Office : 371 Van Ness Way, Suite 120 Torrance, CA, 90501, U. S. A.
Phone : (+1) 310-328-6116, Fax : (+1) 310-328-6252

Midwest Sales : Phone : (+1) 330-334-1115, Fax : (+1) 516-496-3718
Service (+1) 989-345-5379

South Sales : Phone : (+1) 770-972-4724, Fax : (+1) 516-496-3718
Service (+1) 256-774-3777

Parts Center : Phone : (+1) 516-682-4435, Fax : (+1) 516-921-0993
Latin Sales : Phone : (+1) 516-682-4420, Fax : (+1) 516-496-3718

Hitachi Denshi Canada, Ltd. URL: <http://www.hitachidenshi.ca>

Head Office : 1 Select Avenue Unit #11 Scarborough, Ontario M1V 5J3, Canada.
Phone : (+1) 416-299-5900, Fax : (+1) 416-299-0450

Eastern Office : 5795 Chemin St. Francois St. Laurent, Quebec H4S 1B6, Canada
Phone : (+1) 514-332-6687, Fax : (+1) 514-335-1664

Hitachi Denshi (Europa) GmbH

Head Office : Weskircher Straße 88, Jügesheim D-63110 Rodgau, Germany
Phone : +49 (0) 6106-69920, Fax : +49 (0) 6106-16906

URL: www.hitachi-denshi.de
General email address : webmaster@hitachi-denshi.de

Hitachi Denshi (U. K.) Ltd.

Head Office : 14 Garrick Industrial Centre, Irving Way, Hendon, London, NW9 6AQ, United Kingdom
Phone : +44 (0) 208-202-4311, Fax : +44 (0) 208-202-2451

Leeds Office : Brookfield House, Selby Road, Garforth, Leeds LS25 1NB United Kingdom
Phone : +44 (0) 113-287-4400, Fax : +44 (0) 113-287-4260

URL: www.hitachi-denshi-uk.com
General email address : sales@hitachi-denshi-uk.com



CERTIFICATE No.
JMI-0062
ISO 9001/BS 5750Pt1
EN 29001/JIS Z9901